

SERIES F-104

SERIES F-104-GW

Single Point Tab and Gold Wire Bonding

with GW Groove (FL)

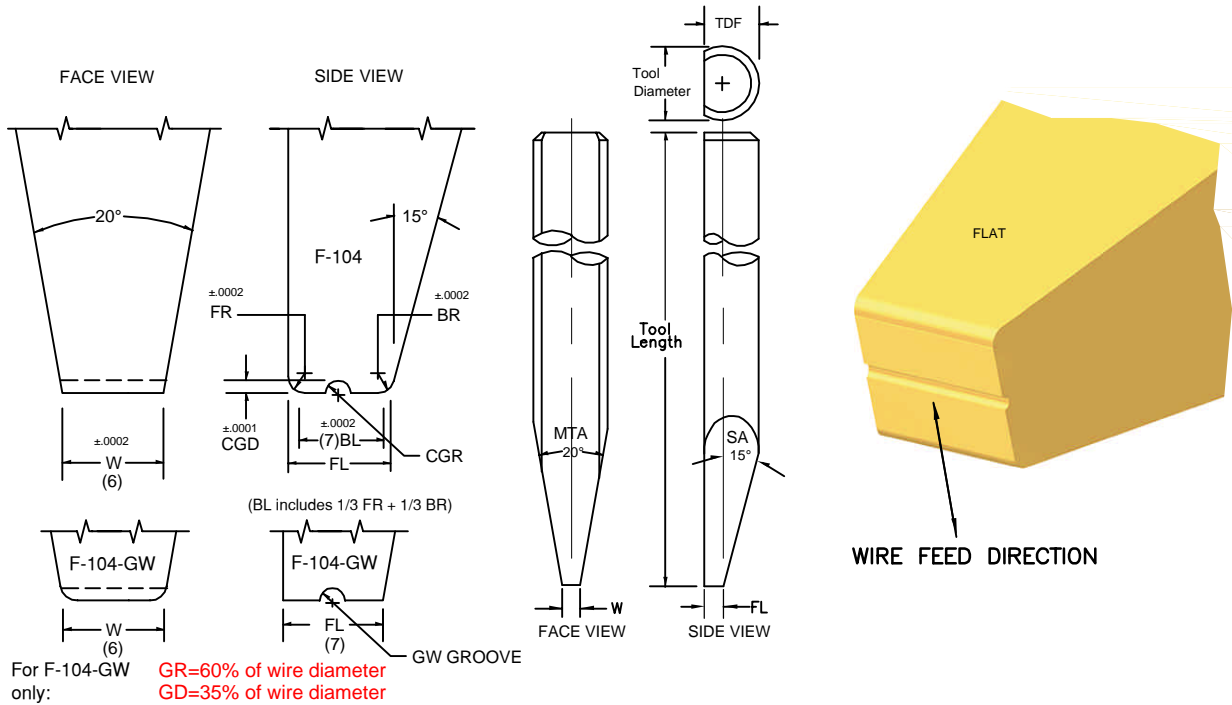

SERIES F-104-GW (WITH GW GROOVE IN FL RADIUS ON W)

MTA = MAIN TAPER ANGLE
SA = SIDE VIEW ANGLE

Special dimensions available upon request.
Dimensions not shown please specify.

We recommend ceramic material for all gold wire bonding for optimum results.

	TD		TDF	
	in.	mm	in.	mm
1/16	.0624	1.59	.0460	1.17
	.0784	1.99	.0630	1.60
3/32	.0937	2.38	.0880	2.24
	.1180	3.00	.0985	2.50
1/8	.1249	3.17	.0937	2.38
1/8	.1249	3.17	.1180	3.00

SAMPLE PART NUMBER: M-F-104-1/16-1-.004-.004-M-E-.001

SYMBOL EXPLANATION: 1 2 3 4 5 6 7 8 9 10

- MATERIAL:** M = Ceramic, C = Tungsten Carbide, T = Titanium, All other: Material Selection Guide **Tool Tips**
- SERIES:** F
- STYLE:** 104 or 104-GW
- TOOL DIAMETER:** Please specify
- TOOL LENGTH:** Please specify
- FOOT WIDTH: (W)** Please specify
- FOOT or BOND LENGTH:** F104 (BL) / F104-GW (FL), For F104 only: Please specify (include 1/3 FR + 1/3 BR)
- FOOT FINISH:** M = Matte, better coupling for thermosonic gold bonding; P = Polished FR, BR, & Bond Flat for thermocompression gold bonding; MP = Polished FR, BR, and Matte Bond Flat. For ultrasonic aluminum bonding.
- FRONT/BACK RADIUS:** See Option Chart below. Optional Radius on W and FL insert B-B or E-E etc.
- only for F104-GW** Please specify wire size GR=60% of wire diameter GD=35% of wire diameter

Optional Radius on W, LR and RR insert a second letter (E-E) in place (.9), **Standard** Radius on FL, FR and BR only

RADIUS OPTION CHART	OPTION LETTER		in.	A	B	C	D	E	F	G	H	I	J	K	L	M	N	
	FRONT RADIUS	LEFT RADIUS		FR	LR	FR	LR	FR	LR	FR	LR	FR	LR	FR	LR	FR	LR	FR
			μ	13	13	25	25	25	38	38	38	38	51	51	51	51	51	51
			in.	0	.0005	0	.0005	.0010	0	.0005	.0010	.0015	0	.0005	.0010	.0015	0	0
			μ	0	13	0	13	25	0	13	25	38	0	13	25	38	51	51